

## PROIECTOR LED 50W

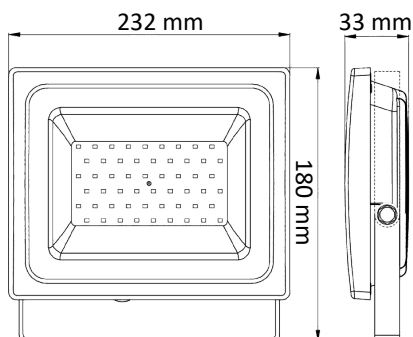

### Dimensiuni



### Caracteristici

- Greutate și dimensiune optimizate datorită designului compact
- Disponibil cu unghi de fascicul: 100°
- Lumină omogenă

### Specificații tehnice

Aplicații	Parcări, treceri subterane, garaje, grădini
Grad de protecție	IP65
Tensiune de alimentare	220-240V / 50-60 Hz
Putere	50 W
Flux luminos	4200 lm
Unghi fascicul	100°
Randamentul corpului de iluminat	85 lm/W
Temperatură de culoare	6500 K
Carcasă	Aluminiu
Factor putere	>0.95
Durata de viață	50.000 h
Cod produs	ST00590

